

Hose Carrier HCP

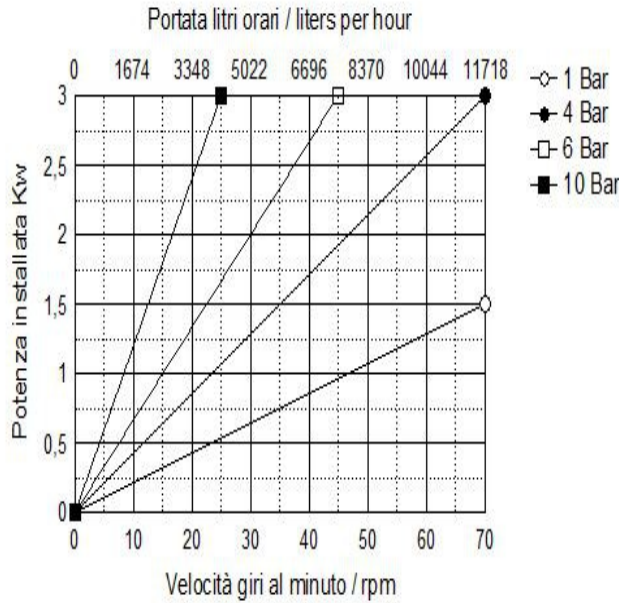

TECNICAL DATA	
Delivery max	12000 I/HOUR
Head max*	10 bar
Vacuum	0,95 bar
Delivery per revolution	2,79 liters
Barb hose	DN 60
Free passage	50 mm
Weight	
Power Kw	1,0-3,0
Hose fiber reinforced available in different materials	NR
	NBR
	HYP
	EPDM
	NRA
Leakage sensor	Option
Cooling device	Option
Different connections	Option

VERSIONS AVAILABLE

- Variables with mechanical speed variator, from 1:5
- Variable electronic inverter integrated IP 65
- Trailers for slow hand towing in site
- Electrical control panels aboard the machine

Note: in the presence of fluids particularly viscous, suspensions coarse solid, high delivery pressure, high temperatures, consider operate not more than 30 % of the maximum flow rate of the pump. *According to the transmission applied

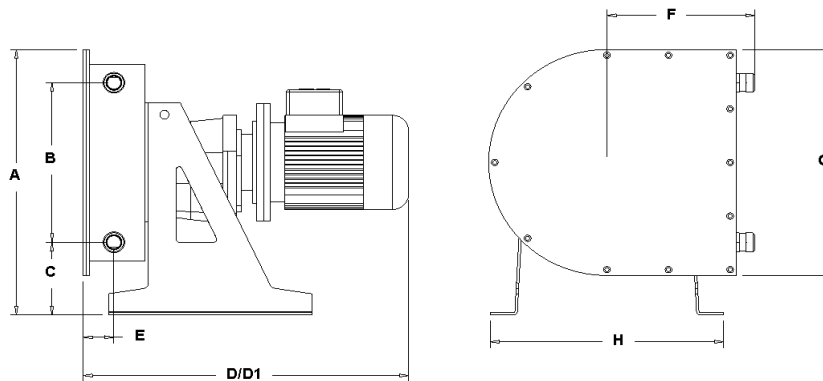

DIMENSIONS											
A	B	C	D	D1(VAR)	E	F	G	H	I	Out/in	Weight
780	524	170	723	931	81	418	696	598	-	DN 60	

Le dimensioni non sono impegnative e possono variare senza avviso

STELLA OM SAS

Via Manzoni 46

20080 VERMEZZO

Italy

Ph. +39 (0)2 9440839

Fax +39 (0)2 9440386

stellaom@virgilio.it