

Hose Carrier HCP

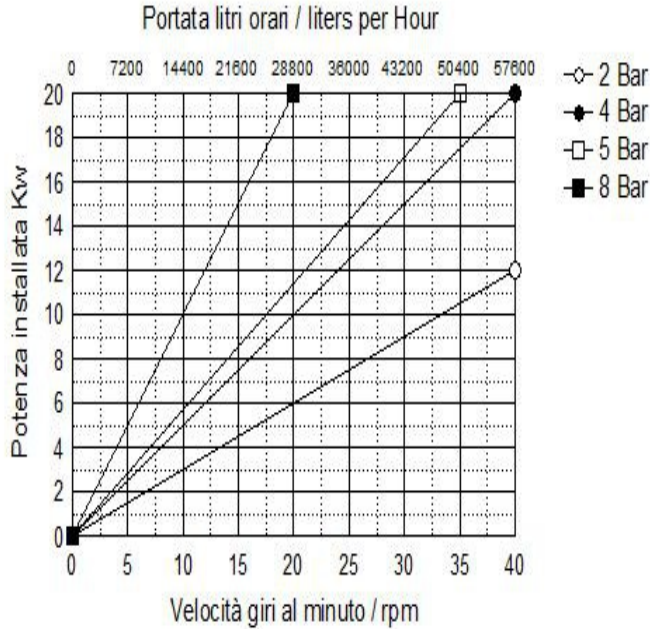

TECNICAL DATA	
Delivery max	60000 l/hour
Head max*	8 bar
Vacuum	0,95 bar
Delivery per revolution	24 liters
Barb Hose	DN 100
Free passage	100 mm
Weight	
Power Kw	5,5-18,5
Hose fiber reinforced available in different materials	NR
	NBR
	HYP
	EPDM
	NRA
Leakage sensor	Option
Cooling device	Option
Different connections	Option

VERSIONS AVAILABLE

Variables with mechanical speed variator, from 1:5

Variable electronic inverter integrated IP 65

Trailers for slow hand towing in site

Electrical control panels aboard the machine

Note: in the presence of fluids particularly viscous, suspensions coarse solid, high delivery pressure, high temperatures, consider operate not more than 30 % of the maximum flow rate of the pump. *According to the transmission applied

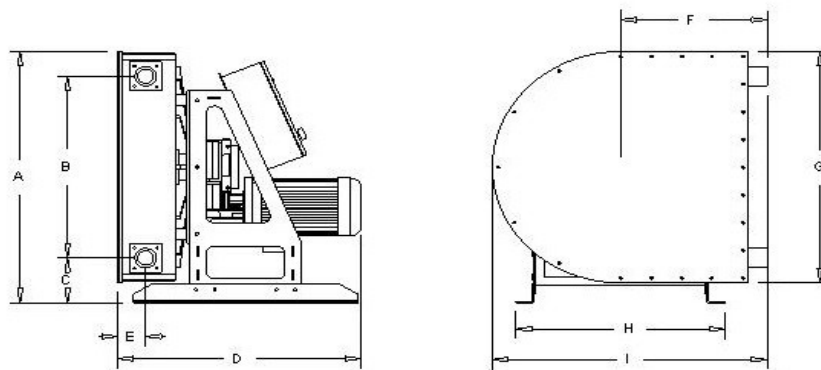

DIMENSIONS											
A	B	C	D	D1(VAR)	E	F	G	H	I	Out/In	Weight
1490	1076	265	1300	-	148	785	1370	1118	1470	DN 100	

The dimensions are not binding and can vary without notice