

**Hose Carrier HC**

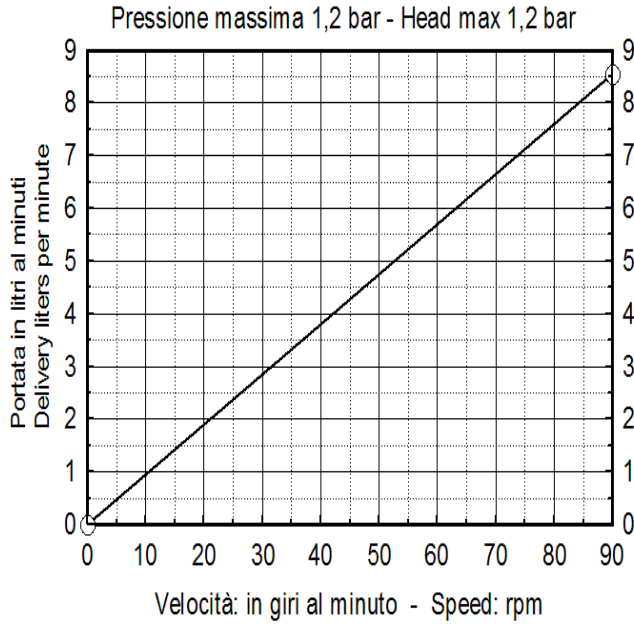

TECHNICAL DATA	
Delivery max	513 l/hour
Head max	1 bar
Vacuum	0,8 bar
Delivery per revolution	0,095 liter
Barb Hose	DN 25
Free passage	20 mm
Weight	
Power Kw	0,18-0,37
Tube available in different materials	TPK
	SIL
	VIT
Leakage sensor	Option
Cooling device	Option
Different connections	Option

VERSIONS AVAILABLE
Variables with mechanical speed variator, from 1:5
Variable electronic inverter integrated IP 56
Trailers for slow hand towing in site
Electrical control panels

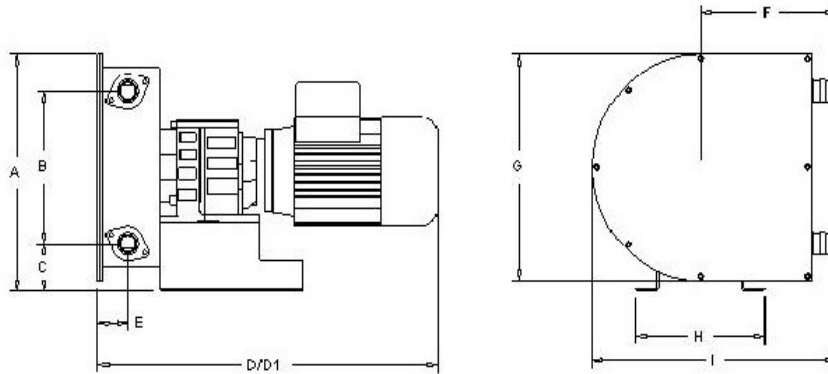

DIMENSIONS											
A	B	C	D	D1(VAR)	E	F	G	H	I	Out/In	Weight
260	167	52	395	540	34,5	158	248	150	282	DN25	

The dimensions are not binding and can vary without notice

STELLA OM SAS  
Via Manzoni 46  
20080 VERMEZZO  
Italy  
Ph. +39 (0)2 9440839  
Fax +39 (0)2 9440386  
stellaom@virgilio.it