

Hose Carrier HC

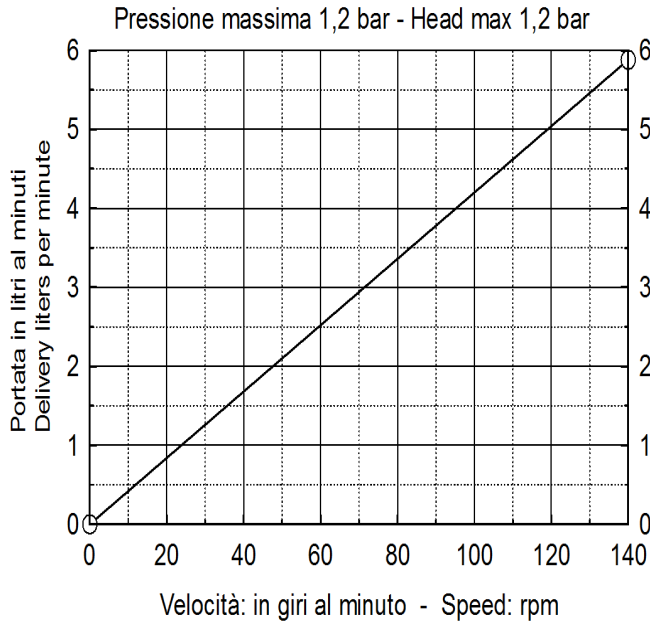

TECHNICAL DATA	
Delivery max	352 l/hour
Head max	1,2 bar
Vacuum	0,8 bar
Delivery per revolution	0,0425 liter
Barb hose	DN 20
Free passage	13 mm
Weight	
Power Kw	0,09 – 0,22
Tube available in different materials	TPK
	SIL
	VIT
Leakage sensor	Option
Cooling device	Option
Different connections	Option

VERSIONS AVAILABLE
Variables with mechanical speed variator, from 1:5
Variable electronic inverter integrated IP 56
Trailers for slow hand towing in site
Electrical control panels

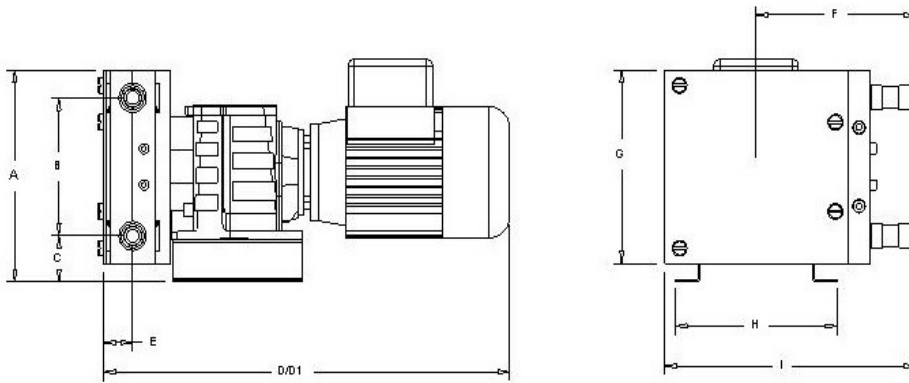

DIMENSIONS											
A	B	C	D	D1(VAR)	E	F	G	H	I	Out/In	Weight
175	114	38	355	455	25,5	140	160	142	220	DN20	

The dimensions are not binding and can vary without notice

STELLA OM SAS

Via Manzoni 46

20080 VERMEZZO

Italy

Ph. +39 (0)2 9440839

Fax +39 (0)2 9440386

stellaom@virgilio.it