

**Hose Carrier HCP**

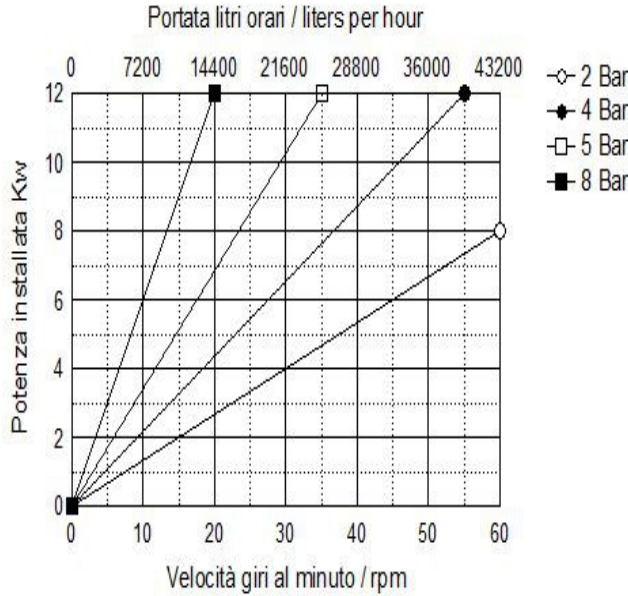

TECHNICAL DATA	
Delivery max	43200 L/Hour
Head max*	8 bar
Vacuum	0,95 bar
Delivery per revolution	12 liters
Barb hose	DN 80
Free passage	80 mm
Weight	
Power Kw	4,0-11
Hose fiber reinforced available in different materials	NR
	NBR
	HYP
	EPDM
	NRA
Leakage sensor	Option
Cooling device	Option
Different connections	Option

VERSIONS AVAILABLE
Variables with mechanical speed variator, from 1:5
Variable electronic inverter integrated IP 65
Trailers for slow hand towing in site
Electrical control panels aboard the machine

Note: in the presence of fluids particularly viscous, suspensions coarse solid, high delivery pressure, high temperatures, consider operate not more than 30 % of the maximum flow rate of the pump. \*According to the transmission applied

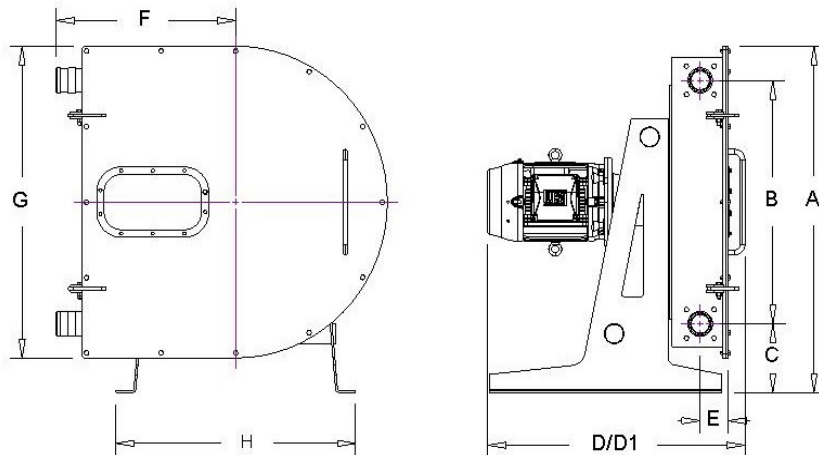

DIMENSIONS											
A	B	C	D	D1(VAR)	E	F	G	H	I	Out/in	Weight
1370	968	272	1050	-	113	735	1240	980	-	DN 100	

The dimensions are not binding and can vary without notice

**STELLA OM SAS**  
 Via Manzoni 46  
 20080 VERMEZZO  
 Italy  
 Ph. +39 (0)2 9440839  
 Fax +39 (0)2 9440386  
 stellaom@virgilio.it