

Hose Carrier HCP

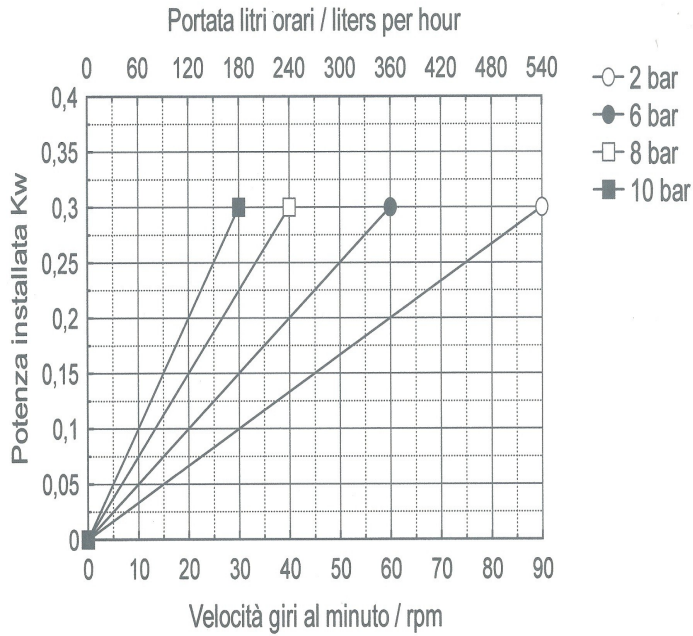

TECHNICAL DATA	
Delivery max	540 l/Hour
Head max*	10 bar
Vacuum	0,95 bar
Delivery per revolution	0,1 liters
Barb hose	DN 20
Free passage	15 mm
Weight	
Power Kw	0,09-0,37
Hose fiber reinforced available in different materials	NR
	NBR
	HYP
	EPDM
	NRA
Leakage sensor	Option
Cooling device	Option
Different connections	Option

VERSIONS AVAILABLE

- Variables with mechanical speed variator, from 1:5
- Variables with electronic inverter integrated IP 65
- Trailers for slow hand towing in site
- Electrical control panels aboard the machine

Note: in the presence of fluids particularly viscous, suspensions coarse solid, high delivery pressure, high temperatures, consider operate not more than 30 % of the maximum flow rate of the pump. *According to the transmission applied

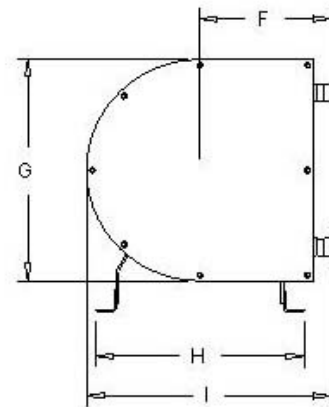
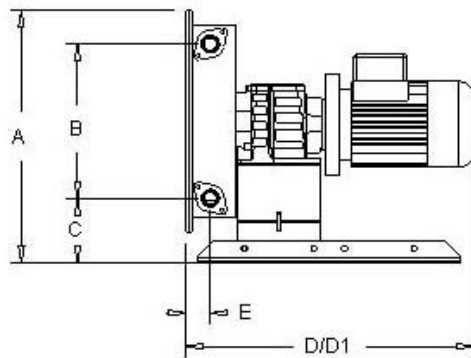

STELLA OM SAS
Via Manzoni 46
20080 VERMEZZO
Italy
Ph. +39 (0)2 9440839
Fax +39 (0)2 9440386
stellaom@virgilio.it

DIMENSIONS

A	B	C	D	D1(VAR)	E	F	G	H	I	Out/In	Weight
355	216	90	393	540	33	178	310	284	334	DN20	

The dimensions are not binding and can vary without notice